

March 2024

## Deciding if Purlins Can Run Through the RTU Opening

When ordering a building with roof top units, several pieces of information will be required in order to provide the most economical solution and also provide the correct RTU opening requirement. While weight, size, and location are crucial information to have, a small detail that's just as important is if purlins are allowed to run through the RTU opening. Here are some tips to help answer this question on your next building with RTUs.

The first detail to look at is the weight of your RTU. American Buildings guidance requires that any RTU weighing more than 1,000 lbs. should have independent framing members. These members are usually built-up or hot rolled beams used to support the heavier RTU loads. This type of framing requires purlins to be cut, so there is little benefit for allowing purlins to run through the opening.

The second detail to consider is what clear areas are required by your RTU. If your opening must remain unobstructed due to air supply and return or you don't know what is required, our recommendation is to not allow roof secondary through the opening. American Buildings engineers will put purlins at the RTU jambs leaving the entirety of the framed opening unobstructed. This will avoid any future fouling between RTU mechanical elements and roof purlins. This will cause the adjacent, uncut purlins to be used to support both the RTU and loads from the cut purlins attached to the RTU jambs. This may require heavier purlins or even independent framing members to be used.

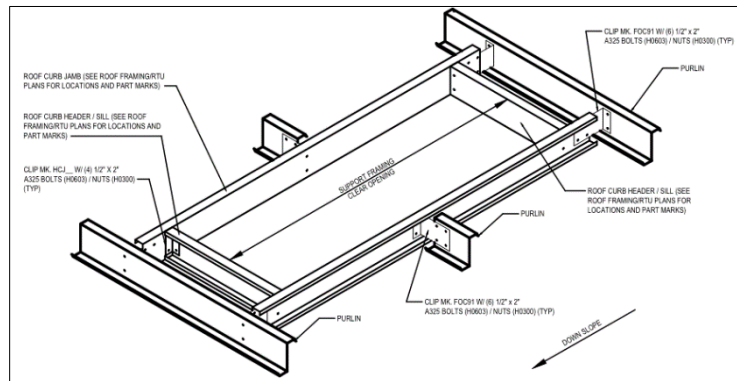

If your RTU is less than 1,000 lbs. and fouling of mechanical elements is not a concern, our recommendation is to allow purlins through the opening. By selecting “yes”, your engineer will design the roof as economically as possible using the increased strength of unbroken purlin runs to support the RTU wherever possible. This can eliminate heavier RTU framing members while maintaining the full strength of unbroken purlin runs in your roof.

